

Preliminary

EN

# MHL 380



245 kW



220 kW



68.0–71.8 t



max. 22.0 m



**FUCHS**<sup>®</sup>

A TEREX BRAND

## TECHNICAL DATA

Operating Weight without Attachments		
MHL380 F	68.0–71.8 t	
Diesel Engine		
	EU Stage V/ U.S. Tier 4	EU Stage IIIA/ U.S. Tier 3*
Manufacturer and model	Deutz TCD 7.8 L6	Deutz TCD 7.8 L6
Design	6-cylinder in-line engine	6-cylinder in-line engine
Functionality	4-stroke diesel, common rail direct injection, turbocharged with intercooler, controlled exhaust gas recirculation, diesel particulate filter with continuous regeneration and SCR catalytic converter	4-stroke diesel, common rail direct injection, turbocharged with intercooler
Engine power	245 kW	245 kW
Rated speed	2,000 rpm	2,000 rpm
Displacement	7.8 l	7.8 l
Cooling system	Water and charge air cooling with temperature controlled fan speed	Water and charge air cooling with temperature controlled fan speed
Exhaust emission standard	EU Stage V/ U.S. Tier 4	EU Stage IIIA/ U.S. Tier 3*
Fuel tank	692 l Diesel	692 l Diesel
DEF / Urea tank	50 l AdBlue	□
Electric Motor		
Power	220 kW	
Total connected load	270 kW	
Motor start	Via soft start	
Optional cable reel	Up to 50 metres (other lengths on request)	
Electrical System		
Alternator	28 V / 100 A	
Operating voltage	24 V	
Battery	2 × 12 V / 110 Ah / 750 A	
Lighting system	2 × LED floodlights at the front of the machine, rear parking lights and indicator lights	
Optional equipment	30 kW DC generator with insulation monitoring	
Travel Drive		
Hydrostatic drive through infinitely variable axial piston motor and directly mounted travel brake valves, all-wheel drive		
Travel speed	0–9 km/h	
Gradeability	max. 25 %	
Turning radius	10.6 m	
Swing Drive		
Slewing ring	Internally geared double row slewing ring bearing, greasing via automatic lubrication system	
Drive	2-stage planetary gear with integrated multi-disc brake	
Uppercarriage swing speed	0–5 rpm infinitely variable	
Slewing lock	Electrically activated	

\* for low-regulated markets

Undercarriage		
Front axle	Planetary drive axle with integrated drum brake, rigidly mounted	
Rear axle	Planetary drive axle with integrated drum brake, oscillating axle with selectable oscillating lock	
Outriggers	4-point stabilizers	
Tyres	Solid rubber 8-ply 14.00-24	
Brakes		
Service brake	Hydraulically operated braking system, acting on all four wheel pairs	
Parking brake	Electrically operated disc brake, acting on both axles	
Hydraulic System		
Max. pump capacity	1 × 560 lpm and 1 × 150 lpm (for swing drive)	
Max. operating pressure	320 / 360 bar	
Hydraulic oil tank	531 l	
Filtration	Flow-optimized return filters, integrated in the oil tank. Filter fineness defined at a beta value β(10) = 200 guarantees 99.5% separation of dirt particles with 10 µm. Very good separation values are already achieved with particle sizes of 3 µm. Generously dimensioned for long operating times.	
Tool control	Infinitely adjustable pressures for the grab functions open, close and rotation, as well as adjustable flow for the function grab rotation via the display	
Cooling system	Separated high-performance cooler with temperature-dependent fan drive	
Operator's Cab		
Cab	Infinitely variable hydraulic height-adjustable cabin with sliding door. Reinforced steel structure, soundproofed, heat-insulated panoramic windows for best all-round visibility, front window with roller blind, glass panel in the cabin roof with sliding blind. Heating and air conditioning, separate heat exchangers, fresh and recirculated air filters. Multifunction touch display, bottle holder, paper clip and multiple storage and mounting options. Digital radio (DAB+, USB, Bluetooth and hands-free), USB charging station 5V. Vertically adjustable cabin: viewing height of 6.14 m. Vertically and horizontally adjustable cabin (option): 2.2 m forward, with max. viewing height of 6.47 m	
Air conditioning	Automatic air-conditioning. Infinitely variable heating with 8-speed fan, 10 adjustable air nozzles, 3 defroster nozzles.	
Operator's seat	Air-cushioned comfort seat with swinging armrests / joysticks, safety belt, lumbar support and headrest. Enables fatigue-free work due to universal adjustment options for the seat position, seat inclination and the arrangement of the seat cushion in relation to the armrests and joysticks.	
Monitoring	Ergonomically arranged, glare-free Multifunction display. Automatic monitoring and storage of deviating operating states (e.g. all hydraulic oil filters, hydraulic oil temperature – coolant and charge air temperature – diesel particulate filter loading, steering), visual and audible warning. Diagnostic option for the individual sensors via the multifunction display. Rear view and side view camera on the right with separate monitor.	
	EU Stage V/ U.S. Tier 4	EU Stage IIIA/ U.S. Tier 3*
Noise level	Sound power level (ambience) L <sub>WA</sub> 102.7 dB(A) (metered) acc. to directive 2000/14/EC L <sub>WA</sub> 104 dB(A) (guaranteed) acc. to directive 2000/14/EC	Sound power level (ambience) L <sub>WA</sub> 102.9 dB(A) (metered) acc. to directive 2000/14/EC L <sub>WA</sub> 104 dB(A) (guaranteed) acc. to directive 2000/14/EC
	Sound pressure level (inside the cabin) acc. to directive ISO 6396 L <sub>PA</sub> 71 dB(A)	Sound pressure level (inside the cabin) acc. to directive ISO 6396 L <sub>PA</sub> 70 dB(A)
Vibrations	Weighted r.m.s. value of acceleration of upper limbs: under 2.5 m/s <sup>2</sup> (98 in/s <sup>2</sup> ) Weighted effective value of acceleration for the seat and feet: under 0.5 m/s <sup>2</sup> (20 in/s <sup>2</sup> )	
Certified in accordance with CE regulations		

## EQUIPMENT

Diesel Engine	Standard	Option
Water and charge air cooler	●	
Temperature-dependent fan drive	●	
Reversible fan		●
Direct electronic fuel injection / common rail	●	
DEF injection, passive regeneration	●	
Advanced automatic idle incl. engine shut-off function	●	
ECO and Power Mode	●	
Engine preheating		●
Engine diagnostics interface	●	
Undercarriage		
All-wheel drive	●	
Disk brakes	●	
Rear axle oscillating lock	●	
4-point stabilizers	●	
Stabilizer cylinder with integrated, double-sided shut-off valves	●	
Piston rod protection for support cylinder	●	
Tool box	●	
Special paint		●
Solid rubber 8-ply 14.00-24	●	
Uppercarriage		
Separated high-performance cooling system	●	
Hydraulic oil cooler with temperature-dependent fan drive	●	
Reversible fan		●
Automatic central lubrication system	●	
Rear view camera	●	
Side view camera	●	
Travel alarm		●
Electric refuelling pump		●
Light protection		●
Special paint		●
Operator's Cab		
Vertically adjustable cabin	●	
Vertically and horizontally adjustable cabin		●
Single-pane safety glass (ESG)	●	
Cabin tinted windows (side, rear)	●	
Sliding window in cab door	●	
Cabin with penetration resistant glass front and top (classification P5A)		●
Cabin with bullet-proof glass (classification P8B)		●

Operator's Cab	Standard	Option
Windshield washer system	●	
Washing device for roof window		●
Roof window clear glass	●	
Air-cushioned operator seat with headrest, seatbelt and lumbar support	●	
Seat heating		●
Joystick steering	●	
Steering column, height and tilt adjustable		●
Air Conditioner	●	
Auxiliary heating incl. timer		●
Multi-function display	●	
Document clip	●	
FOPS Guard		●
Cabin front and top guard		●
12 V transformer		●
Digital radio (DAB+, USB, Bluetooth and hands-free system)	●	
12V socket / cigarette lighter		●
Fire extinguisher, dry powder with holder		●
Travel alarm with rotating beacon		●
Other Equipment		
30 kW DC generator		●
Close proximity range limiter for dipper stick	●	
Coolant and hydraulic oil level monitoring system	●	
Overload and working area control		●
Filtration system for attachments		●
Rupture valves for lifting cylinders	●	
Rupture valves for stick cylinders	●	
Overload warning device		●
Quick coupling on dipper stick	●	
Active cyclone prefilter		●
Hydraulic oil preheating		●
Lubrication of the grab suspension by central lubrication system	●	
LED head lights at the front of the machine	●	
LED light packages		●
Float switch		●
Tool control	●	
Fuchs Connect telematics system, incl. 5 years contract	●	

**DIMENSIONS**

**Vertically adjustable cabin**

**Side view**  
all dimensions in mm

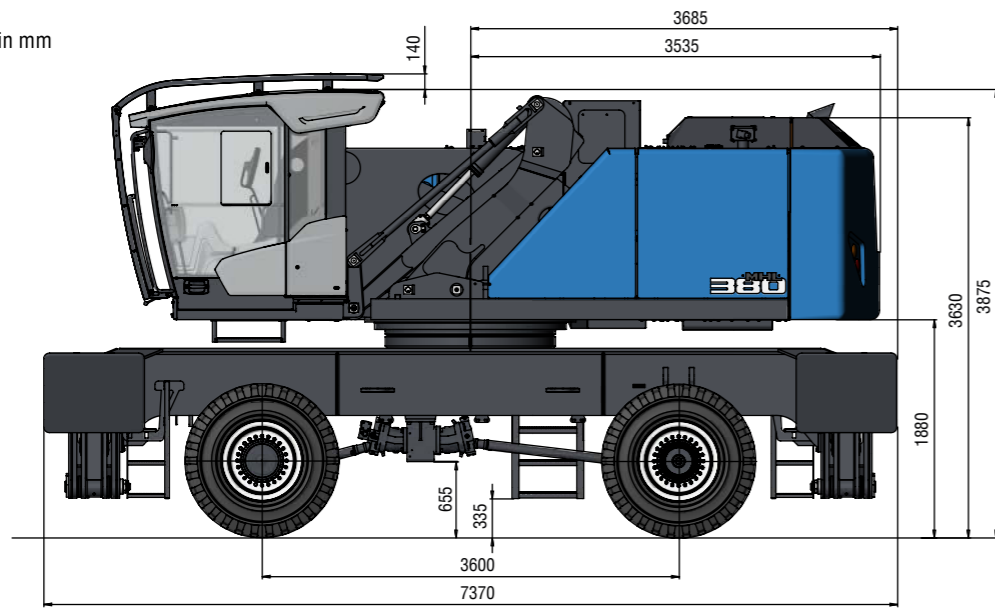

**Side view**  
all dimensions in mm

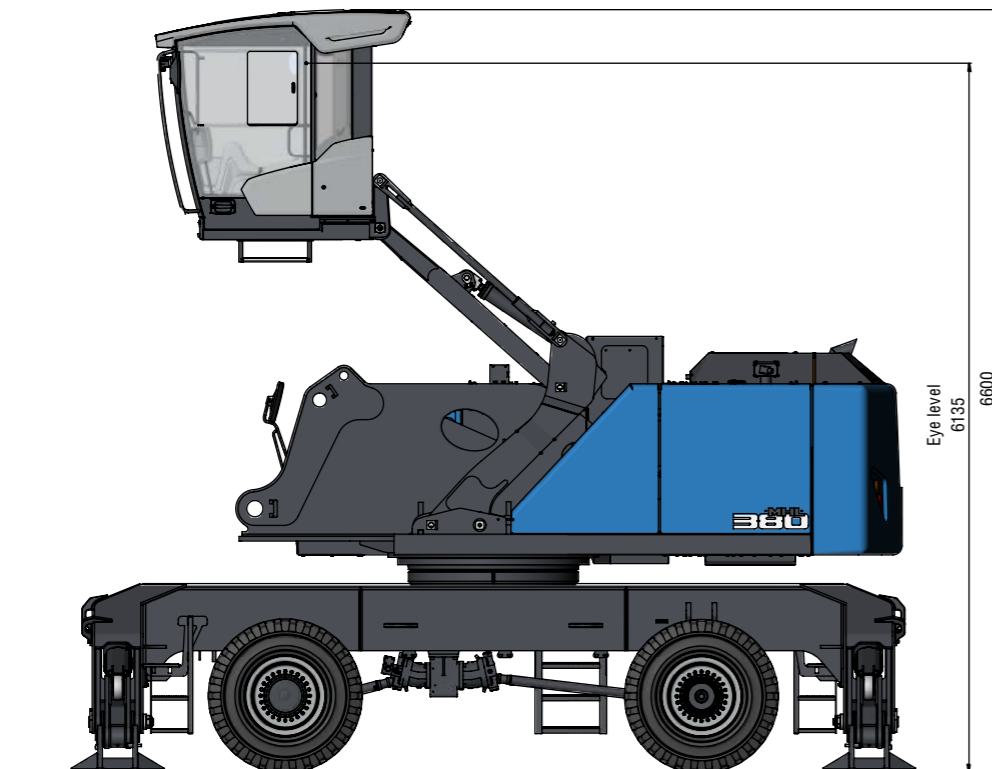

**DIMENSIONS**

**Vertically and horizontally adjustable cabin\***

**Side view**  
all dimensions in mm

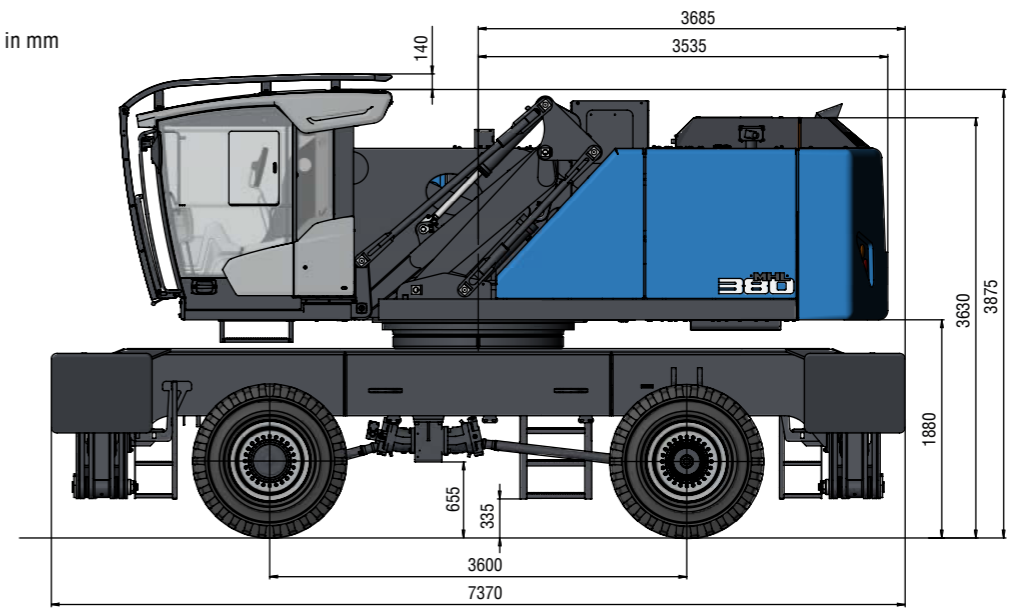

**Side view**  
all dimensions in mm

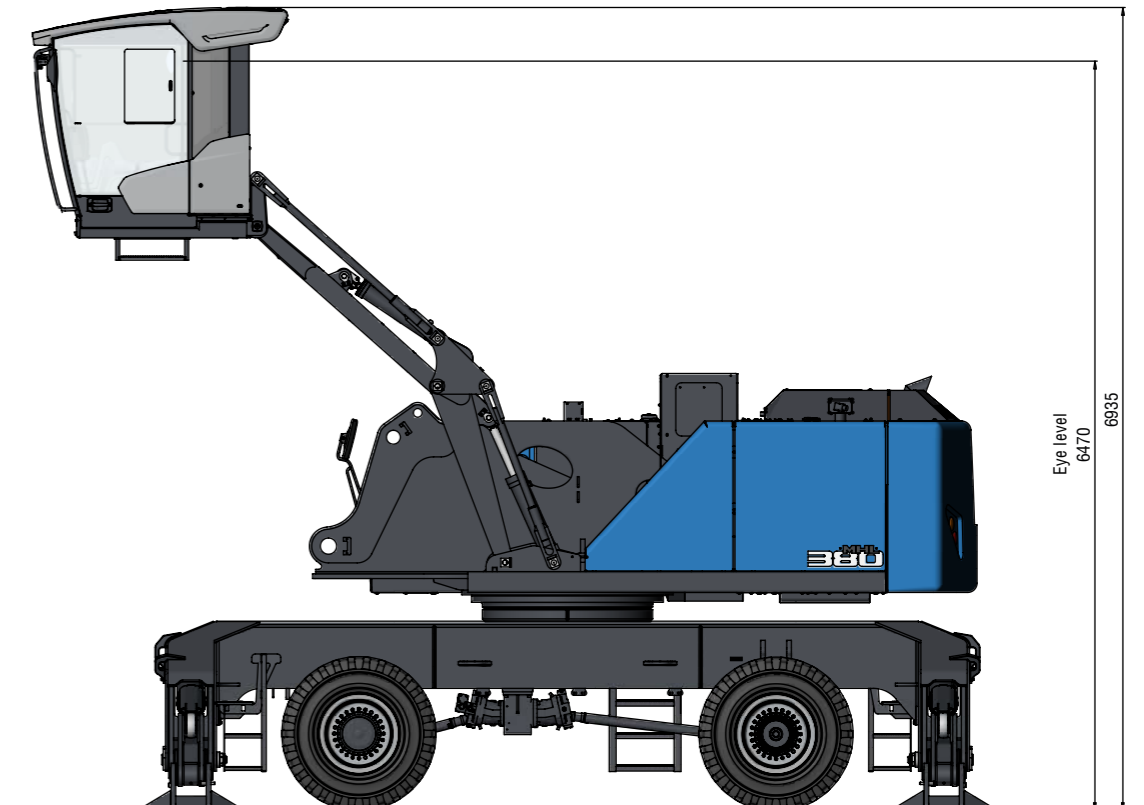

\* Option

## DIMENSIONS

### Front view

all dimensions in mm

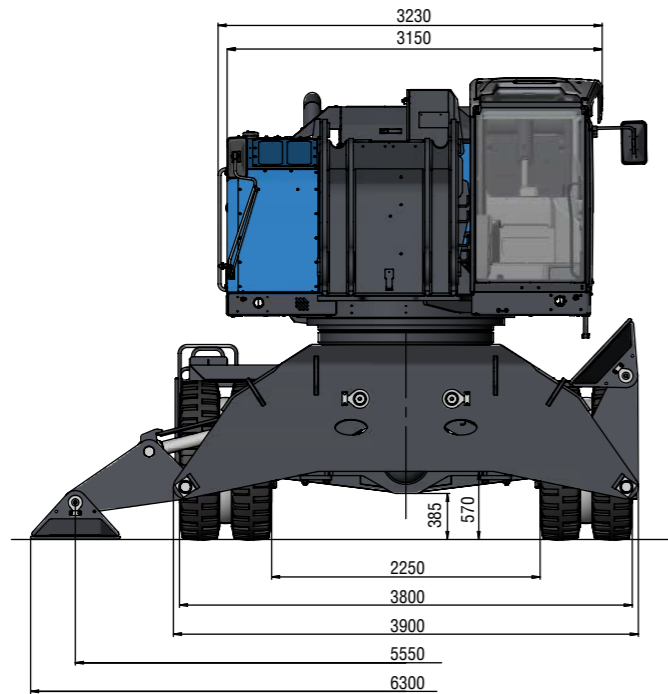

### Front view with catwalk

all dimensions in mm

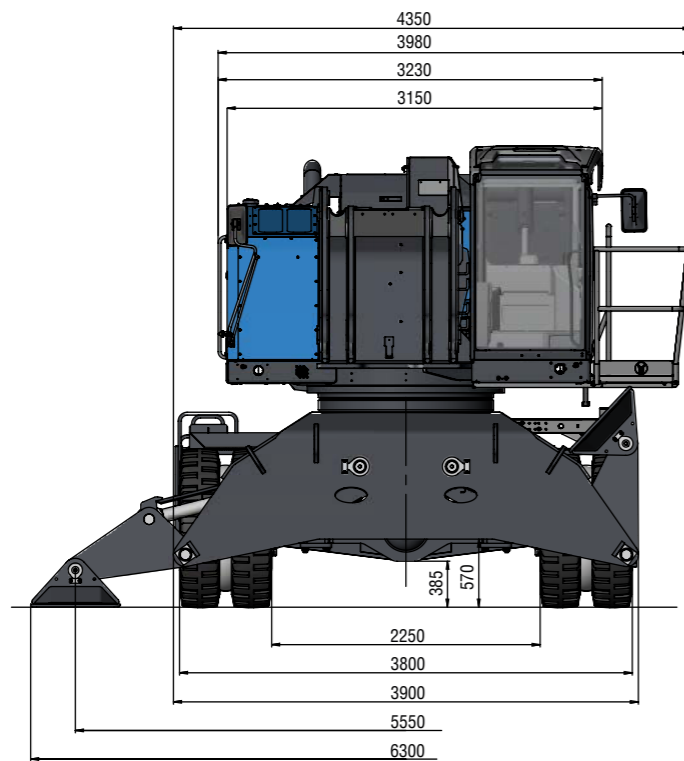

## TRANSPORT DIMENSIONS

### Loading equipment with dipper stick

all dimensions in mm

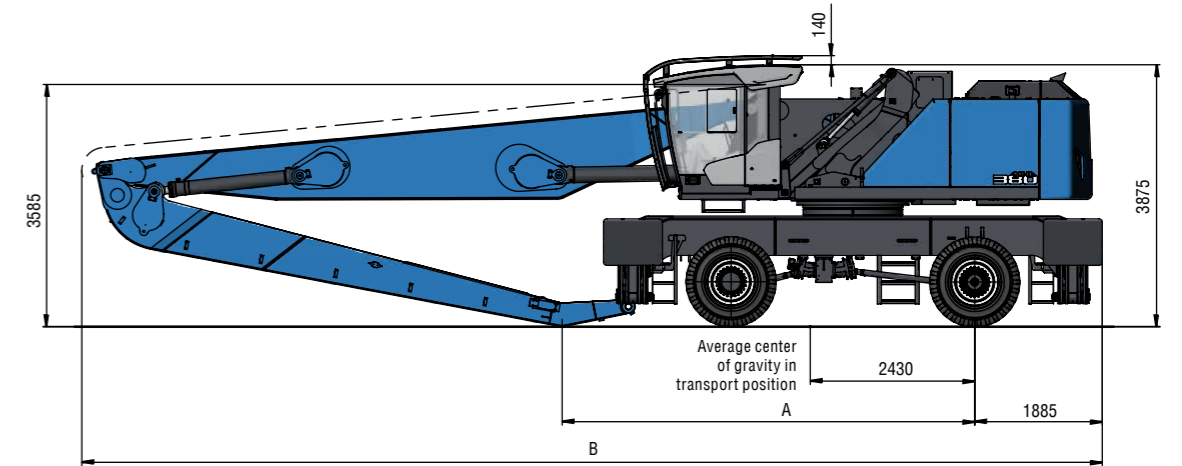

Reach	18 m	20 m	22 m
A	6100 mm	7935 mm	5720 mm
B	15080 mm	16975 mm	17010 mm

### Loading equipment with banana boom

all dimensions in mm

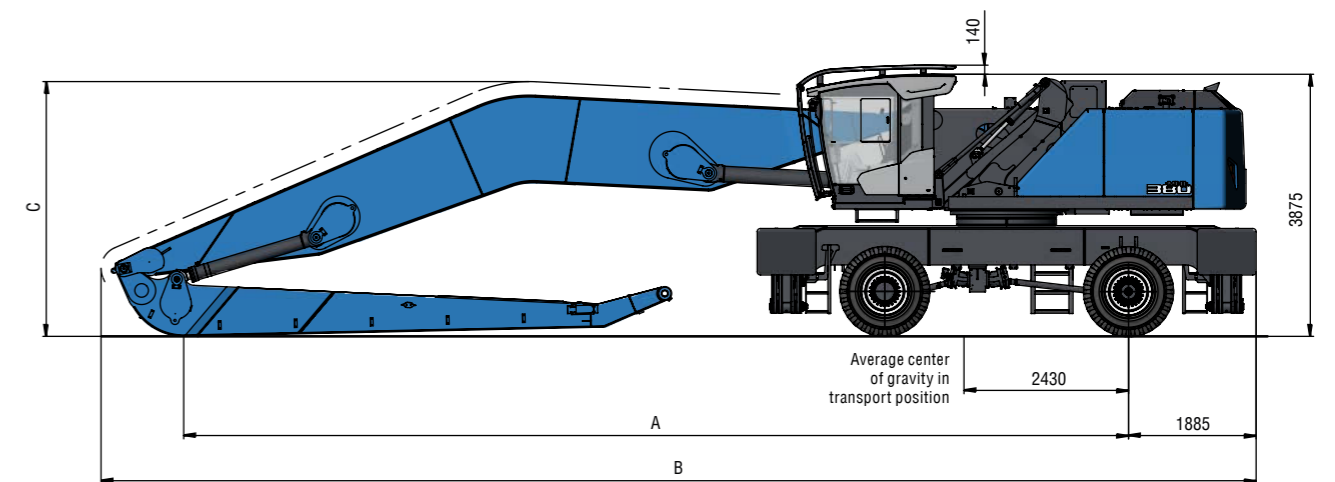

Reach	20 m	22 m
A	13955 mm	9725 mm
B	17065 mm	17070 mm
C	3765 mm	3785 mm

REACH



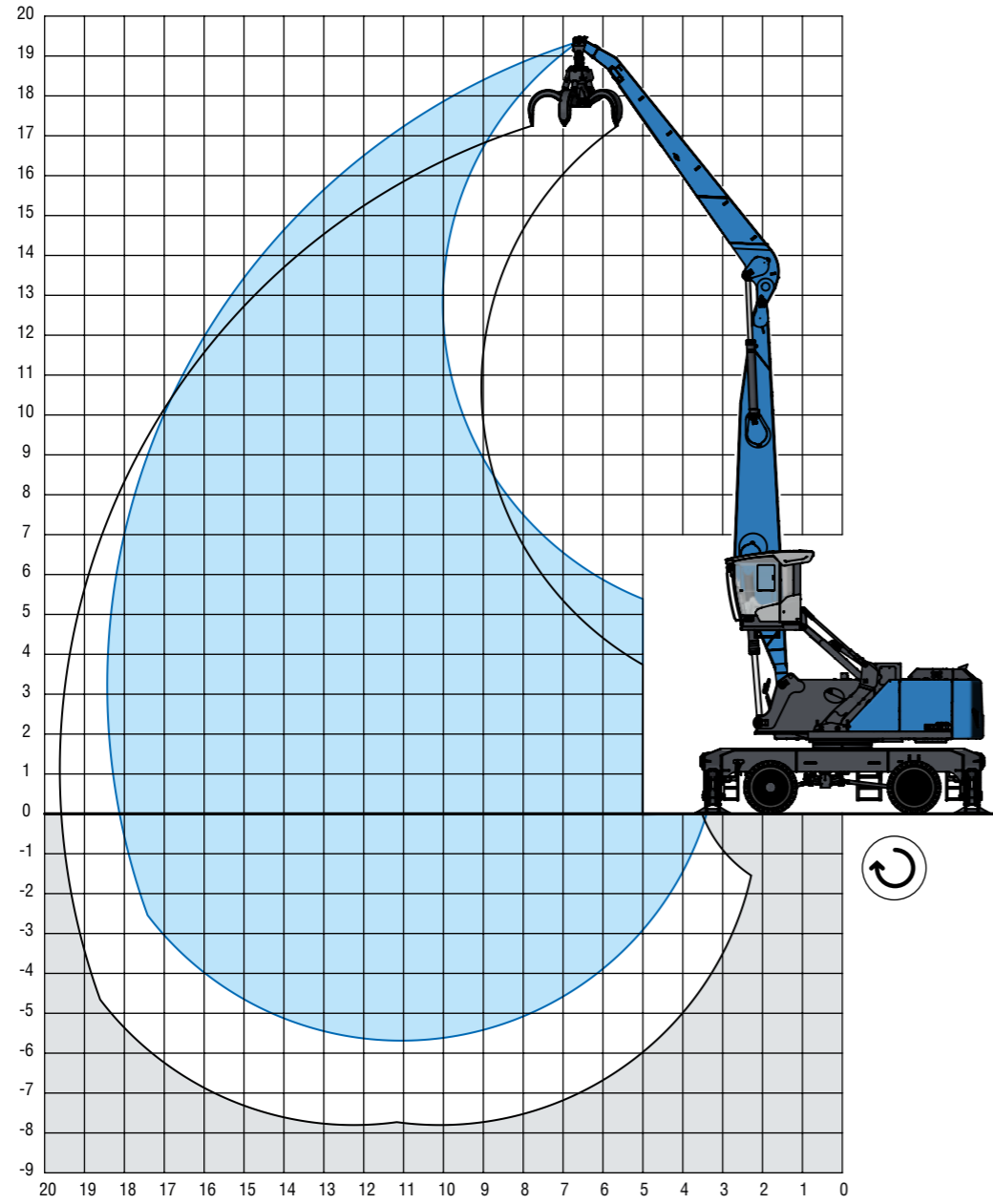

18 m with dipper stick

Boom: 9.6 m · Dipper stick: 8 m · Cactus grab: 0.8 m<sup>3</sup>



[m]

LIFTING CAPACITY

		  									
		6 m	7.5 m	9 m	10.5 m	12 m	13.5 m	15 m	16.5 m	18 m	
18 m		8.6° (8.6°)									
16.5 m		9.3° (9.3°) 6.6° (6.6°)									
15 m		10.9° (10.9°) 9.2° (9.2°) 6.5° (6.5°)									
13.5 m		11.3° (11.3°) 10.1° (10.1°) 8.8° (8.8°) 5.5° (5.5°)									
12 m		12.1° (12.1°) 11.2° (11.2°) 9.8° (9.8°) 7.9° (7.9°)									
10.5 m		12.6° (12.6°) 11.7° (11.7°) 10.8° (10.8°) 9.0° (9.0°) 6.1° (6.1°)									
9 m		14.4° (14.4°) 13.1° (13.1°) 11.9° (11.9°) 11.0° (11.0°) 10.1 (10.2°) 7.9° (7.9°)									
7.5 m		15.5° (15.5°) 13.7° (13.7°) 12.4° (12.4°) 11.2° (11.2°) 10.0 (10.3°) 8.5 (8.7°)									
6 m		18.6° (18.6°)	19.9° (19.9°)	16.7° (16.7°)	14.5° (14.5°)	12.8° (12.8°)	11.5° (11.5°)	9.8 (10.5°)	8.3 (9.5°)	5.8° (5.8°)	
4.5		20.0 (20.0)	20.0 (20.0)	18.0° (18.0°)	15.3° (15.3°)	13.3° (13.3°)	11.3 (11.8°)	9.5 (10.6°)	8.2 (9.6°)	6.7° (6.7°)	
3 m		20.0 (20.0)	20.0 (20.0)	19.1° (19.1°)	16.0° (16.0°)	13.1 (13.7°)	10.9 (12.1°)	9.3 (10.7°)	8.0 (9.5°)	7.1° (7.1°)	
1.5 m		10.5° (10.5°)	20.0 (20.0)	19.3 (19.9°)	15.3 (16.4°)	12.6 (14.0°)	10.6 (12.2°)	9.1 (10.7°)	7.9 (9.4°)	6.9° (6.9°)	
0 m		8.9° (8.9°)	18.3° (18.3°)	18.5 (20.0)	14.8 (16.5°)	12.3 (14.0°)	10.4 (12.1°)	8.9 (10.5°)	7.8 (9.1°)	6.1° (6.1°)	
-1.5 m		9.0° (9.0°)	15.5° (15.5°)	18.1 (19.5°)	14.5 (16.2°)	12.0 (13.7°)	10.2 (11.7°)	8.8 (10.1°)	7.7 (8.5°)		
-3 m		9.7° (9.7°)	14.9° (14.9°)	17.9 (18.3°)	14.3 (15.3°)	11.9 (12.9°)	10.1 (11.0°)	8.8 (9.3°)	7.5° (7.5°)		
-4.5 m			15.3° (15.3°)	16.4° (16.4°)	13.9° (13.9°)	11.7° (11.7°)	9.8° (9.8°)				
										max. reach 18.4 m	
3.3 m											4.8° (4.8°)

Recommended attachments upon request



Height



Reach



Center of rotation



4-point supported

The lift capacity values are stated in metric tons (t). In accordance with ISO 10567, the lift capacity values represents 75 % of the static tipping loads or 87% of the hydraulic lifting force (marked \*). On solid and level ground the values apply to a swing range of 360°. The (...) values apply in the longitudinal direction of the undercarriage. The weights of the attached load hoisting equipment (grab, load hook, etc.) must be deducted from the lift capacity values. The working load of the lifting device must be observed. In accordance with the EN 474-5 for object handling application hose rupture valves on the boom and stick cylinders, an overload warning device and the lift capacity table in the cab are required. The machine has to be supported on a level ground for object handling application.

REACH

20 m with dipper stick

Boom: 11.5 m · Dipper stick: 8 m · Cactus grab: 0.8 m³

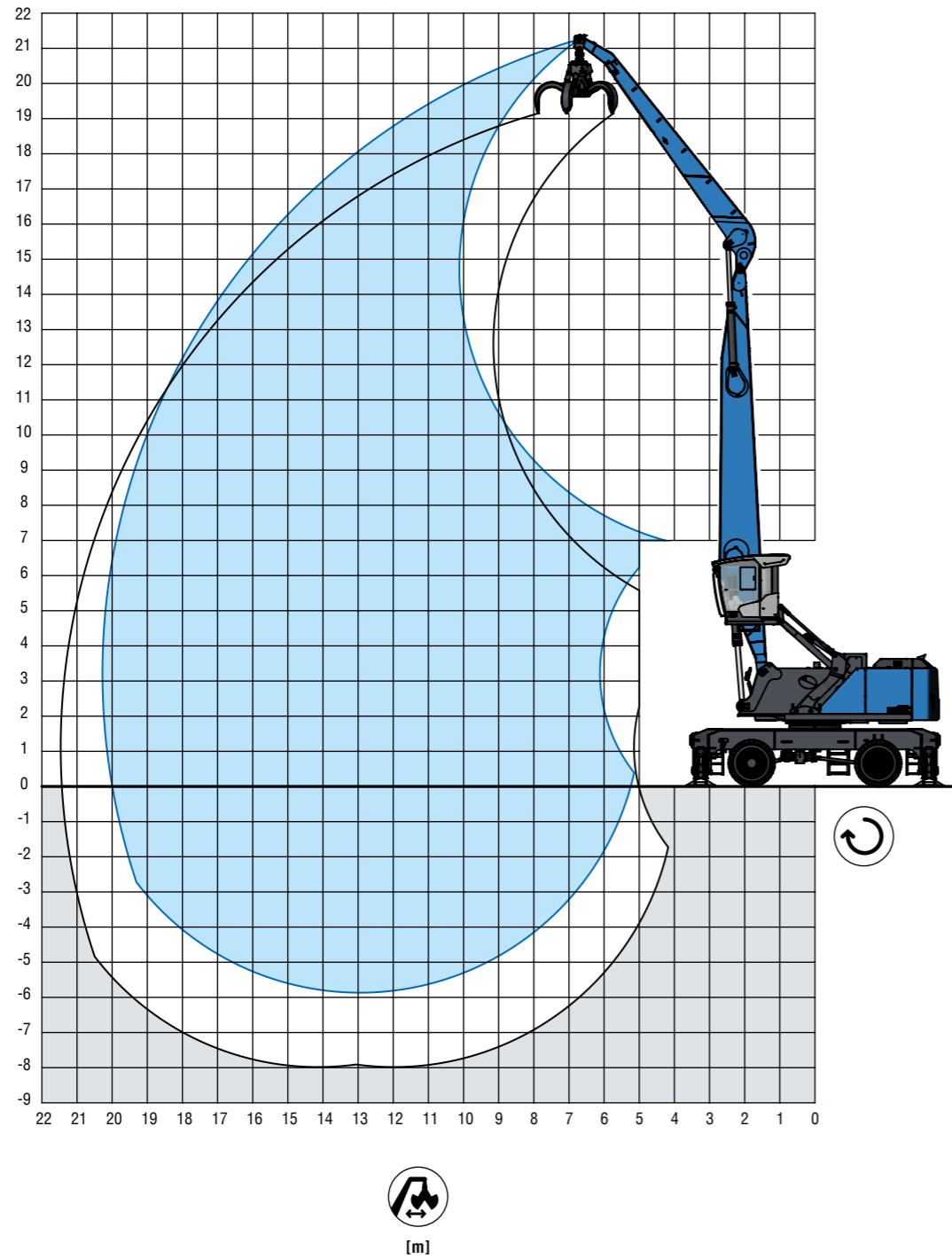

LIFTING CAPACITY

		6 m	7.5 m	9 m	10.5 m	12 m	13.5 m	15 m	16.5 m	18 m	19.5 m
21 m		8.8° (8.8°)									
19.5 m		9.5° (9.5°) 8.0° (8.0°)									
18 m		9.6° (9.6°) 8.4° (8.4°)									
16.5 m		10.7° (10.7°) 9.6° (9.6°) 8.4° (8.4°)									
15 m		11.6° (11.6°) 10.7° (10.7°) 9.5° (9.5°) 8.0° (8.0°)									
13.5 m		12.1° (12.1°) 10.9° (10.9°) 10.0° (10.0°) 9.1° (9.1°) 7.2° (7.2°)									
12 m		12.3° (12.3°) 11.0° (11.0°) 10.0° (10.0°) 9.2° (9.2°) 8.4° (8.4°) 5.5° (5.5°)									
10.5 m		14.4° (14.4°) 12.6° (12.6°) 11.2° (11.2°) 10.2° (10.2°) 9.3° (9.3°) 8.4 (8.5°) 7.0° (7.0°)									
9 m		15.1° (15.1°) 13.1° (13.1°) 11.6° (11.6°) 10.4° (10.4°) 9.4° (9.4°) 8.2 (8.6°) 7.0 (7.9°)									
7.5 m		20.0 (20.0)	19.5° (19.5°)	16.0° (16.0°)	13.6° (13.6°)	11.9° (11.9°)	10.6° (10.6°)	9.5° (9.5°)	8.1 (8.6°)	6.9 (7.9°)	6.1° (6.1°)
6 m		20.0 (20.0)	20.0 (20.0)	17.0° (17.0°)	14.2° (14.2°)	12.3° (12.3°)	10.8° (10.8°)	9.2 (9.7°)	7.9 (8.7°)	6.8 (7.9°)	5.9 (6.7°)
4.5		7.1° (7.1°)	20.0 (20.0)	17.8° (17.8°)	14.7° (14.7°)	12.5 (12.6°)	10.5 (11.0°)	8.9 (9.8°)	7.7 (8.7°)	6.7 (7.8°)	5.8 (7.0°)
3 m		11.5° (11.5°) 18.1 (18.3°) 14.5 (15.1°) 12.0 (12.8°) 10.1 (11.1°) 8.6 (9.8°) 7.5 (8.7°) 6.5 (7.7°) 5.7 (6.8°)									
1.5 m		3.4° (3.4°)	8.2° (8.2°)	17.2 (18.3°)	13.8 (15.1°)	11.5 (12.8°)	9.7 (11.1°)	8.4 (9.7°)	7.3 (8.6°)	6.4 (7.6°)	5.7 (6.5°)
0 m		4.2° (4.2°)	7.7° (7.7°)	14.5° (14.5°)	13.4 (14.9°)	11.1 (12.6°)	9.4 (10.9°)	8.2 (9.5°)	7.1 (8.3°)	6.3 (7.3°)	5.6 (6.1°)
-1.5 m		5.2° (5.2°)	8.0° (8.0°)	13.3° (13.3°)	13.1 (14.2°)	10.9 (12.2°)	9.3 (10.5°)	8.0 (9.1°)	7.0 (8.0°)	6.2 (6.8°)	5.5° (5.5°)
-3 m		8.7° (8.7°) 13.2° (13.2°) 13.0 (13.2°) 10.7 (11.4°) 9.1 (9.9°) 7.9 (8.5°) 7.0 (7.3°) 6.1° (6.1°)									
-4.5 m		13.5° (13.5°) 11.8° (11.8°) 10.3° (10.3°) 8.9° (8.9°) 7.7° (7.7°) 6.4° (6.4°)									
<b>max. reach 20.2 m</b>											
3.3 m		4.8° (4.8°)									

Recommended attachments upon request

- Height
- Reach
- Center of rotation
- 4-point supported

The lift capacity values are stated in metric tons (t). In accordance with ISO 10567, the lift capacity values represents 75 % of the static tipping loads or 87% of the hydraulic lifting force (marked \*). On solid and level ground the values apply to a swing range of 360°. The (...) values apply in the longitudinal direction of the undercarriage. The weights of the attached load hoisting equipment (grab, load hock, etc.) must be deducted from the lift capacity values. The working load of the lifting device must be observed. In accordance with the EN 474-5 for object handling application hose rupture valves on the boom and stick cylinders, an overload warning device and the lift capacity table in the cab are required. The machine has to be supported on a level ground for object handling application.

REACH

22 m with dipper stick

Boom: 11.5 m - Dipper stick: 10 m - Cactus grab: 0.8 m³

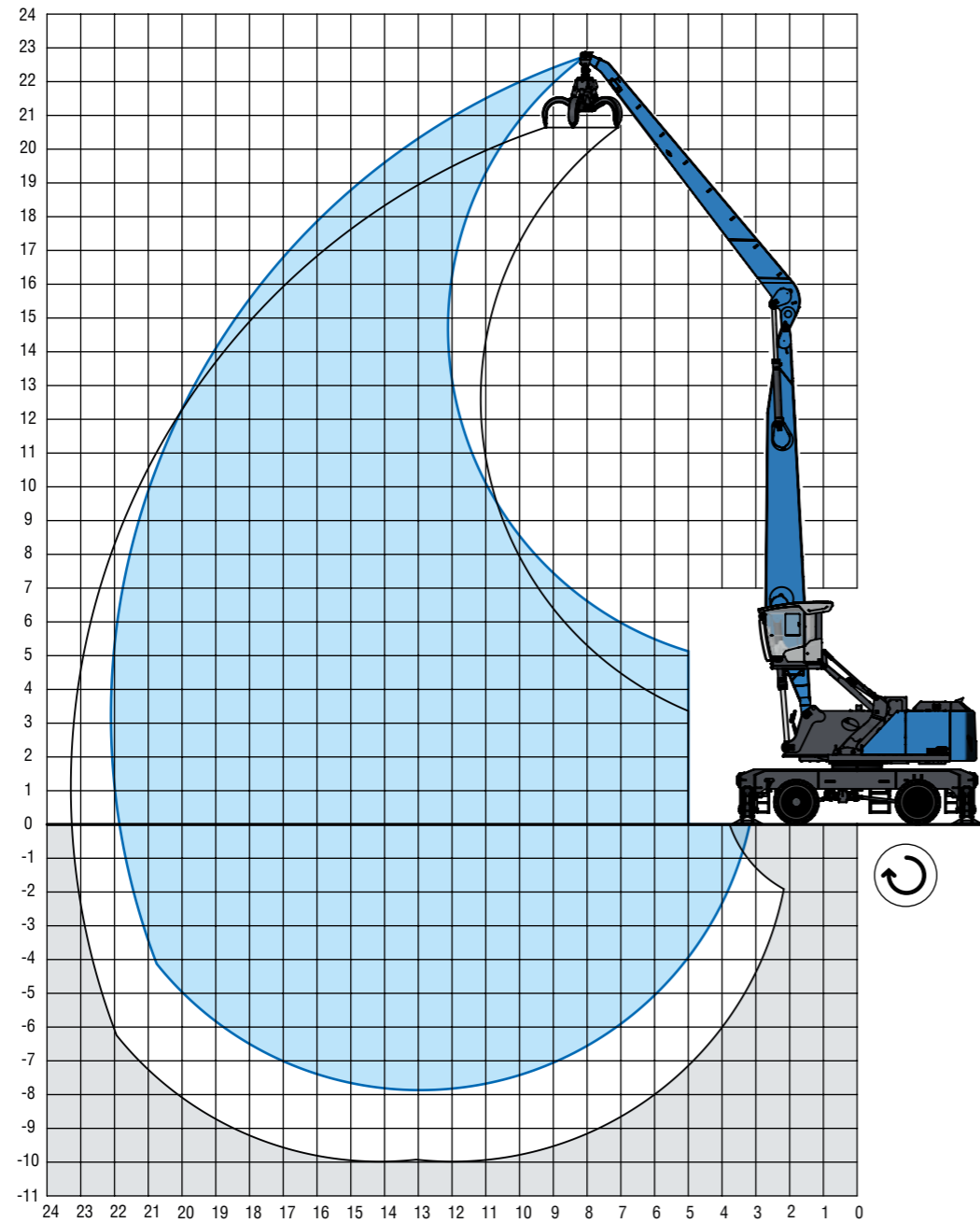

LIFTING CAPACITY

		6 m	7.5 m	9 m	10.5 m	12 m	13.5 m	15 m	16.5 m	18 m	19.5 m	21 m			
22.5 m				6.2° (6.2°)											
21 m				6.8° (6.8°)	5.5° (5.5°)										
19.5 m					6.9° (6.9°)	5.8° (5.8°)									
18 m					7.9° (7.9°)	6.9° (6.9°)	5.8° (5.8°)								
16.5 m					8.5° (8.5°)	7.8° (7.8°)	6.7° (6.7°)	5.4° (5.4°)							
15 m						8.5° (8.5°)	7.6° (7.6°)	6.4° (6.4°)	4.8° (4.8°)						
13.5 m						9.1° (9.1°)	8.3° (8.3°)	7.3° (7.3°)	5.8° (5.8°)						
12 m						10.0° (10.0°)	9.1° (9.1°)	8.5° (8.5°)	7.9° (7.9°)	6.7° (6.7°)	5.1° (5.1°)				
10.5 m						10.2° (10.2°)	9.3° (9.3°)	8.6° (8.6°)	7.9° (7.9°)	7.4° (7.4°)	6.1° (6.1°)				
9 m						11.7° (11.7°)	10.5° (10.5°)	9.5° (9.5°)	8.7° (8.7°)	8.0° (8.0°)	7.3° (7.4°)	6.3° (6.6°)	4.3° (4.3°)		
7.5 m						13.1° (13.1°)	12.3° (12.3°)	10.9° (10.9°)	9.8° (9.8°)	8.9° (8.9°)	8.1° (8.1°)	7.2° (7.5°)	6.2° (6.9°)	5.2° (5.2°)	
6 m						16.1° (16.1°)	15.2° (15.2°)	13.0° (13.0°)	11.4° (11.4°)	10.1° (10.1°)	9.1° (9.1°)	8.2° (8.2°)	7.0° (7.5°)	6.1° (6.9°)	5.3° (5.5°)
4.5 m		20.0 (20.0)	20.0 (20.0)	16.3° (16.3°)	13.7° (13.7°)	11.8° (11.8°)	10.4° (10.4°)	9.2 (9.3°)	7.9 (8.3°)	6.8 (7.6°)	5.9 (6.9°)	5.2 (6.0°)			
3 m		15.0° (15.0°)	20.0 (20.0)	17.2° (17.2°)	14.2° (14.2°)	12.2° (12.2°)	10.5 (10.6°)	8.9 (9.4°)	7.6 (8.4°)	6.6 (7.6°)	5.8 (6.8°)	5.1 (6.1°)			
1.5 m		6.8° (6.8°)	17.0° (17.0°)	17.7° (17.7°)	14.5 (14.6°)	11.9 (12.4°)	10.0 (10.8°)	8.5 (9.5°)	7.4 (8.4°)	6.4 (7.5°)	5.7 (6.7°)	5.0 (5.9°)			
0 m		5.6° (5.6°)	10.8° (10.8°)	17.1 (17.9°)	13.7 (14.7°)	11.4 (12.5°)	9.6 (10.8°)	8.2 (9.4°)	7.1 (8.3°)	6.3 (7.4°)	5.5 (6.6°)	4.9 (5.7°)			
-1.5 m		5.7° (5.7°)	9.3° (9.3°)	16.4 (16.8°)	13.2 (14.5°)	10.9 (12.3°)	9.3 (10.6°)	8.0 (9.3°)	7.0 (8.2°)	6.1 (7.2°)	5.5 (6.3°)	4.9 (5.3°)			
-3 m		6.1° (6.1°)	9.0° (9.0°)	14.4° (14.4°)	12.8 (14.0°)	10.6 (11.9°)	9.0 (10.3°)	7.8 (9.0°)	6.8 (7.8°)	6.0 (6.8°)	5.4 (5.8°)	4.6° (4.6°)			
-4.5 m		6.7° (6.7°)	9.1° (9.1°)	13.6° (13.6°)	12.6 (13.2°)	10.5 (11.3°)	8.9 (9.7°)	7.7 (8.4°)	6.8 (7.3°)	6.0 (6.3°)	5.2° (5.2°)				
-6 m			9.5° (9.5°)	13.6° (13.6°)	12.0° (12.0°)	10.3° (10.3°)	8.8 (8.9°)	7.7° (7.7°)	6.6° (6.6°)	5.4° (5.4°)					
-7.5 m						9.0° (9.0°)	7.7° (7.7°)								
												max. reach 22.1 m			
3.3 m												3.5° (3.5°)			

Recommended attachments upon request

- Height
- Reach
- Center of rotation
- 4-point supported

The lift capacity values are stated in metric tons (t). In accordance with ISO 10567, the lift capacity values represents 75 % of the static tipping loads or 87% of the hydraulic lifting force (marked \*). On solid and level ground the values apply to a swing range of 360°. The (...) values apply in the longitudinal direction of the undercarriage. The weights of the attached load hoisting equipment (grab, load hook, etc.) must be deducted from the lift capacity values. The working load of the lifting device must be observed. In accordance with the EN 474-5 for object handling application hose rupture valves on the boom and stick cylinders, an overload warning device and the lift capacity table in the cab are required. The machine has to be supported on a level ground for object handling application.

REACH

20 m with banana boom

Banana boom: 11.75 m · Dipper stick 8 m · Cactus grab: 0.8 m³

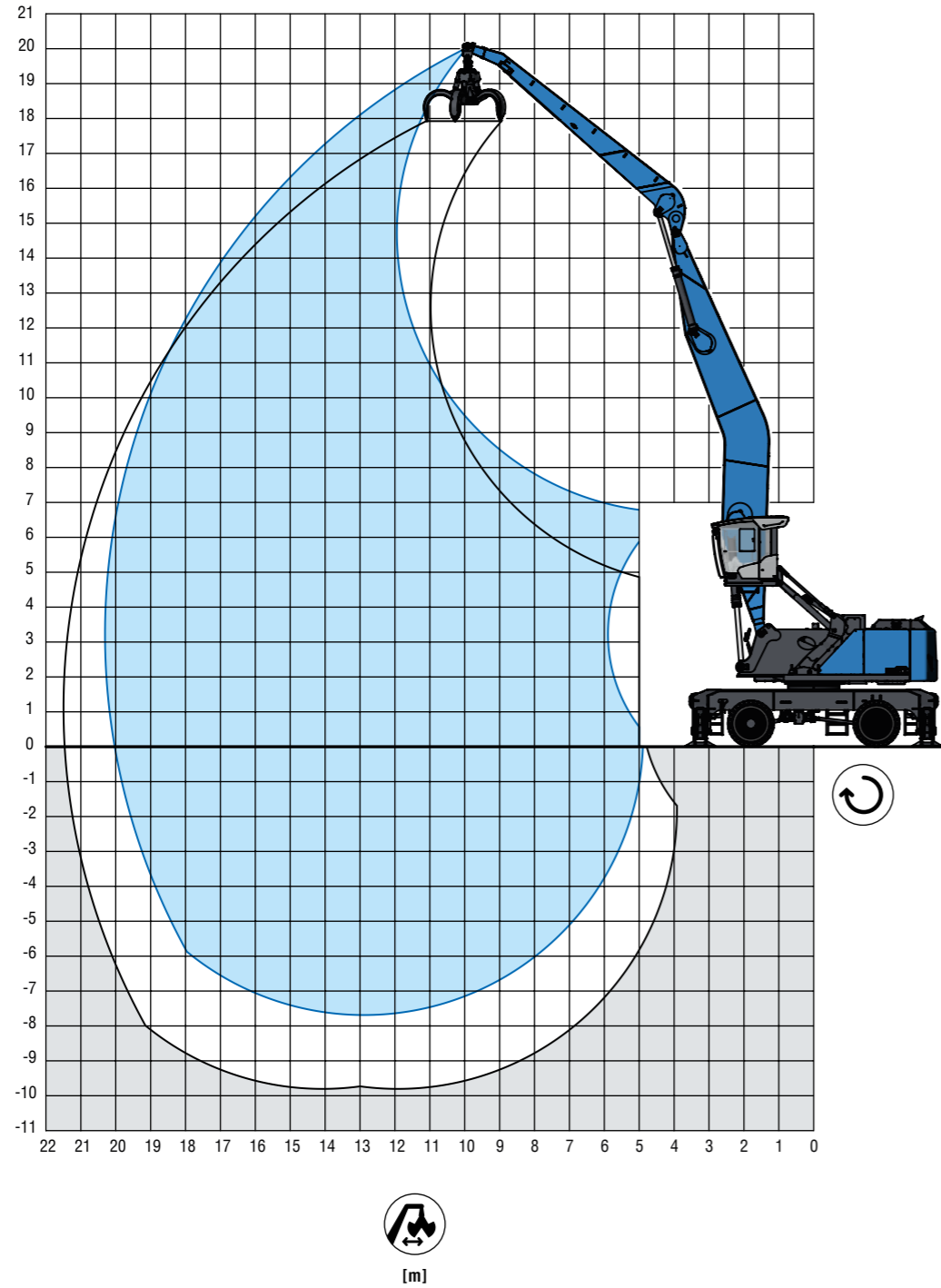

LIFTING CAPACITY

		6 m	7.5 m	9 m	10.5 m	12 m	13.5 m	15 m	16.5 m	18 m	19.5 m
19.5 m					7.0° (7.0°)						
18 m						7.9° (7.9°)					
16.5 m						9.1° (9.1°)	7.9° (7.9°)				
15 m						9.4° (9.4°)	8.7° (8.7°)	7.2° (7.2°)			
13.5 m						9.4° (9.4°)	8.6° (8.6°)	8.0° (8.0°)	6.4° (6.4°)		
12 m						9.5° (9.5°)	8.7° (8.7°)	8.1° (8.1°)	7.5° (7.5°)	5.3° (5.3°)	
10.5 m						9.8° (9.8°)	8.9° (8.9°)	8.2° (8.2°)	7.6° (7.6°)	6.7° (6.7°)	
9 m					11.4° (11.4°)	10.1° (10.1°)	9.1° (9.1°)	8.3° (8.3°)	7.7° (7.7°)	7.0° (7.1°)	
7.5 m			17.1° (17.1°)	14.1° (14.1°)	12.0° (12.0°)	10.5° (10.5°)	9.4° (9.4°)	8.5° (8.5°)	7.8° (7.8°)	6.9° (7.2°)	5.6° (5.6°)
6 m		20.0 (20.0)	18.8° (18.8°)	15.1° (15.1°)	12.7° (12.7°)	11.0° (11.0°)	9.7° (9.7°)	8.7° (8.7°)	7.8 (7.9°)	6.7 (7.2°)	5.8 (6.6°)
4.5		6.5° (6.5°)	20.0 (20.0)	16.0° (16.0°)	13.3° (13.3°)	11.4° (11.4°)	9.9° (9.9°)	8.9° (8.9°)	7.6 (8.0°)	6.6 (7.3°)	5.7 (6.6°)
3 m		3.6° (3.6°)	10.9° (10.9°)	16.8° (16.8°)	13.8° (13.8°)	11.7° (11.7°)	10.0 (10.2°)	8.5 (9.0°)	7.3 (8.1°)	6.4 (7.3°)	5.6 (6.6°)
1.5 m		3.7° (3.7°)	8.2° (8.2°)	16.8 (17.1°)	13.6 (14.1°)	11.3 (11.9°)	9.5 (10.3°)	8.2 (9.1°)	7.1 (8.1°)	6.2 (7.2°)	5.5 (6.5°)
0 m		4.5° (4.5°)	7.7° (7.7°)	13.7° (13.7°)	13.0 (14.1°)	10.8 (11.9°)	9.2 (10.3°)	7.9 (9.1°)	6.9 (8.0°)	6.1 (7.1°)	5.4 (6.3°)
-1.5 m		5.5° (5.5°)	8.0° (8.0°)	12.7° (12.7°)	12.6 (13.9°)	10.5 (11.8°)	8.9 (10.2°)	7.7 (8.9°)	6.8 (7.9°)	6.0 (6.9°)	5.3 (6.0°)
-3 m		6.4° (6.4°)	8.6° (8.6°)	12.5° (12.5°)	12.4 (13.3°)	10.3 (11.4°)	8.8 (9.9°)	7.6 (8.6°)	6.7 (7.6°)	5.9 (6.5°)	
-4.5 m			9.3° (9.3°)	12.9° (12.9°)	12.3 (12.5°)	10.2 (10.8°)	8.7 (9.4°)	7.5 (8.1°)	6.6 (7.0°)	5.9° (5.9°)	
-6 m				13.1° (13.1°)	11.4° (11.4°)	9.9° (9.9°)	8.6° (8.6°)	7.4° (7.4°)	6.2° (6.2°)		
-7.5 m							7.4° (7.4°)				
<b>max. reach 20.3 m</b>											
3.3 m											4.7° (4.7°)

Recommended attachments upon request

- Height
- Reach
- Center of rotation
- 4-point supported

The lift capacity values are stated in metric tons (t). In accordance with ISO 10567, the lift capacity values represents 75 % of the static tipping loads or 87% of the hydraulic lifting force (marked \*). On solid and level ground the values apply to a swing range of 360°. The (...) values apply in the longitudinal direction of the undercarriage. The weights of the attached load hoisting equipment (grab, load hook, etc.) must be deducted from the lift capacity values. The working load of the lifting device must be observed. In accordance with the EN 474-5 for object handling application hose rupture valves on the boom and stick cylinders, an overload warning device and the lift capacity table in the cab are required. The machine has to be supported on a level ground for object handling application.

REACH

22 m with banana boom

Banana boom: 11,75 m · Dipper stick 10 m · Cactus grab: 0,8 m³

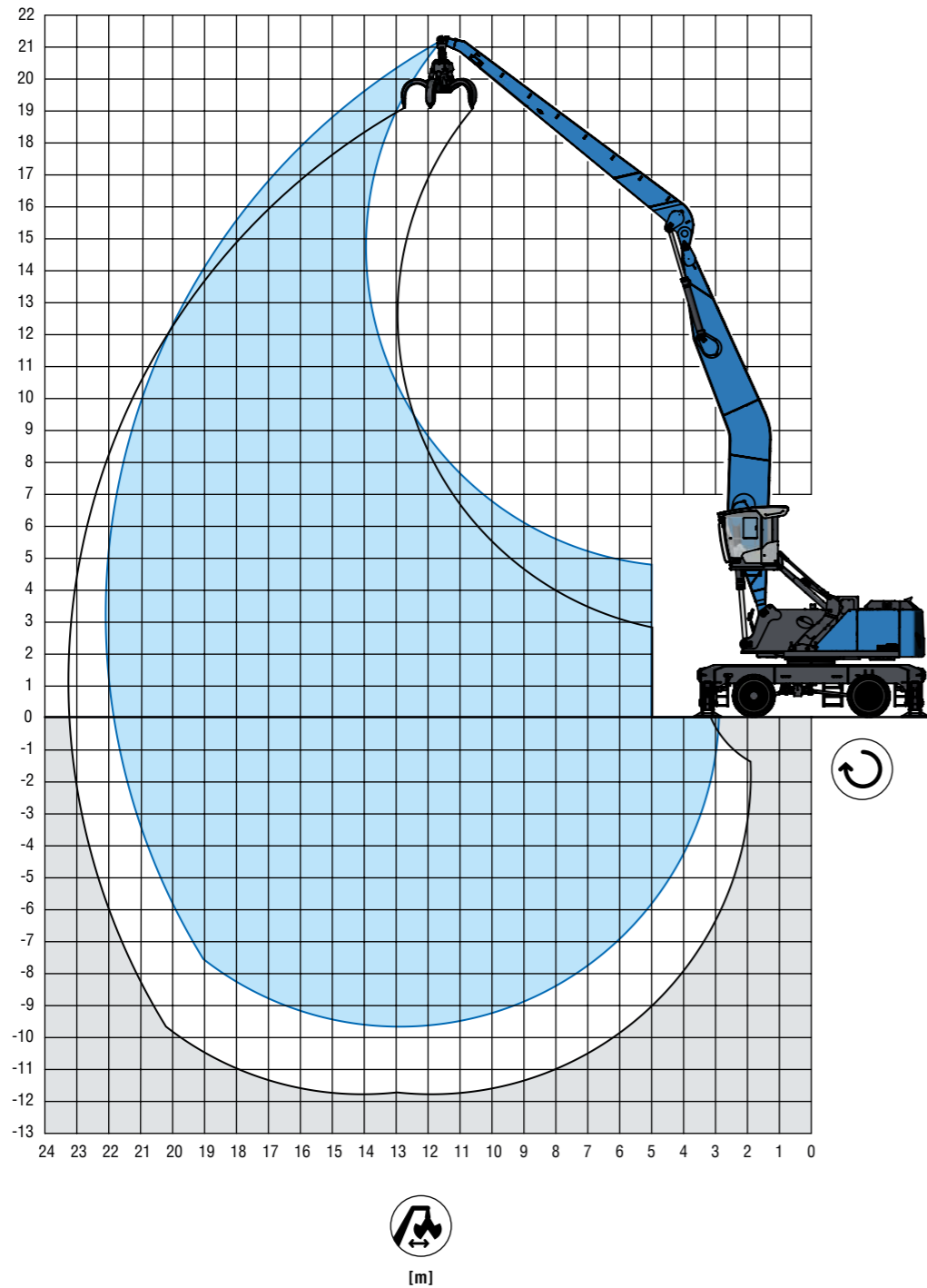

[m]

LIFTING CAPACITY

		6 m	7.5 m	9 m	10.5 m	12 m	13.5 m	15 m	16.5 m	18 m	19.5 m	21 m	
21 m	☞					4.7° (4.7°)							
19.5 m	☞						5.0° (5.0°)						
18 m	☞						6.4° (6.4°)	5.3° (5.3°)					
16.5 m	☞							6.3° (6.3°)	5.1° (5.1°)				
15 m	☞							7.2° (7.2°)	6.0° (6.0°)	4.5° (4.5°)			
13.5 m	☞							7.2° (7.2°)	6.8° (6.8°)	5.4° (5.4°)			
12 m	☞							7.3° (7.3°)	6.8° (6.8°)	6.4° (6.4°)	4.7° (4.7°)		
10.5 m	☞							8.0° (8.0°)	7.4° (7.4°)	6.9° (6.9°)	6.5° (6.5°)	5.4° (5.4°)	
9 m	☞							8.3° (8.3°)	7.6° (7.6°)	7.0° (7.0°)	6.5° (6.5°)	6.1° (6.1°)	4.1° (4.1°)
7.5 m	☞					9.5° (9.5°)	8.5° (8.5°)	7.8° (7.8°)	7.2° (7.2°)	6.6° (6.6°)	6.2° (6.2°)	4.6° (4.6°)	
6 m	☞			13.3° (13.3°)	11.3° (11.3°)	9.9° (9.9°)	8.9° (8.9°)	8.0° (8.0°)	7.3° (7.3°)	6.7° (6.7°)	6.0 (6.2°)	5.2° (5.2°)	
4.5 m	☞	20.0 (20.0)	17.9° (17.9°)	14.4° (14.4°)	12.1° (12.1)	10.4° (10.4°)	9.2° (9.2°)	8.2° (8.2°)	7.5° (7.5°)	6.8° (6.8°)	5.9 (6.3°)	5.1 (5.7°)	
3 m	☞	13.0° (13.0°)	19.5° (19.5°)	15.4° (15.4°)	12.7° (12.7°)	10.9° (10.9°)	9.5° (9.5°)	8.5° (8.5°)	7.6° (7.6°)	6.5 (6.9°)	5.7 (6.3°)	5.0 (5.8°)	
1.5 m	☞	6.8° (6.8°)	15.4° (15.4°)	16.1° (16.1°)	13.2° (13.2°)	11.2° (11.2°)	9.8° (9.8°)	8.4 (8.6°)	7.3 (7.7°)	6.3 (7.0°)	5.5 (6.3°)	4.8 (5.7°)	
0 m	☞	5.8° (5.8°)	10.5° (10.5°)	16.5° (16.5°)	13.5 (13.6°)	11.2 (11.6°)	9.4 (9.9°)	8.1 (8.7°)	7.0 (7.8°)	6.1 (7.0°)	5.4 (6.3°)	4.7 (5.6°)	
-1.5 m	☞	5.8° (5.8°)	9.1° (9.1°)	15.6° (15.6°)	12.8 (13.7°)	10.7 (11.6°)	9.0 (10.0°)	7.8 (8.7°)	6.8 (7.8°)	5.9 (6.9°)	5.2 (6.2°)	4.7 (5.4°)	
-3 m	☞	6.2° (6.2°)	8.8° (8.8°)	13.6° (13.6°)	12.4 (13.5°)	10.3 (11.5°)	8.7 (9.9°)	7.5 (8.6°)	6.6 (7.6°)	5.8 (6.8°)	5.2 (6.0°)	4.5° (4.5°)	
-4.5 m	☞	6.6° (6.6°)	8.9° (8.9°)	12.8° (12.8°)	12.1 (13.1°)	10.0 (11.2°)	8.5 (9.6°)	7.4 (8.4°)	6.5 (7.4°)	5.7 (6.5°)	5.1 (5.6°)		
-6 m	☞	7.1° (7.1°)	9.2° (9.2°)	12.7° (12.7°)	12.0 (12.4°)	9.9 (10.6°)	8.4 (9.2°)	7.3 (8.0°)	6.4 (7.0°)	5.7 (6.0°)	5.0° (5.0°)		
-7.5 m	☞		9.6° (9.6°)	13.0° (13.0°)	11.4° (11.4°)	9.8° (9.8°)	8.4 (8.5°)	7.3° (7.3°)	6.3° (6.3°)	5.3° (5.3°)			
-9 m	☞				10.0° (10.0°)	8.7° (8.7°)	7.5° (7.5°)	6.4° (6.4°)					
												max. reach 22 m	
3.3 m	☞											3.4° (3.4°)	

Recommended attachments upon request

- Height
- Reach
- Center of rotation
- 4-point supported

The lift capacity values are stated in metric tons (t). In accordance with ISO 10567, the lift capacity values represents 75 % of the static tipping loads or 87% of the hydraulic lifting force (marked \*). On solid and level ground the values apply to a swing range of 360°. The (...) values apply in the longitudinal direction of the undercarriage. The weights of the attached load hoisting equipment (grab, load hook, etc.) must be deducted from the lift capacity values. The working load of the lifting device must be observed. In accordance with the EN 474-5 for object handling application hose rupture valves on the boom and stick cylinders, an overload warning device and the lift capacity table in the cab are required. The machine has to be supported on a level ground for object handling application.

# MODULAR SYSTEM

## Attachments



Cactus grab



Timber grapple



Magnet plate

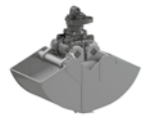

Clamshell grab



Load hook

## Work Equipment

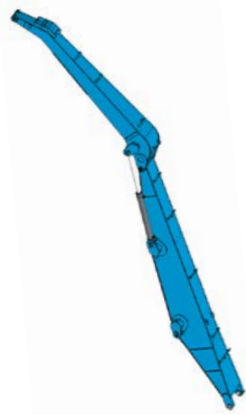

Straight

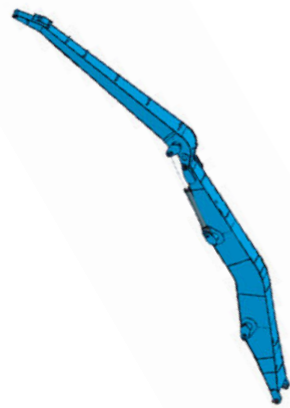

Banana boom

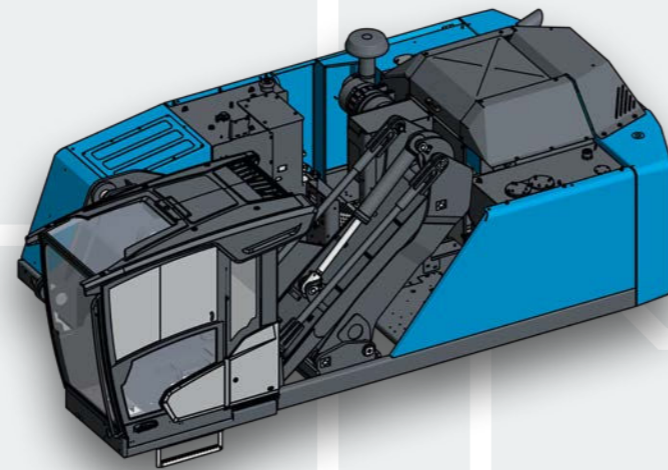

## Cab Systems



Vertically adjustable



Vertically and horizontally adjustable

## Engines

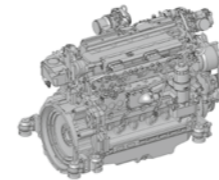

Diesel engine

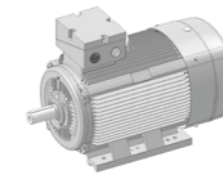

Electric motor

## Options



Cable reel

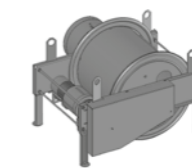

Cable drum

## Undercarriage

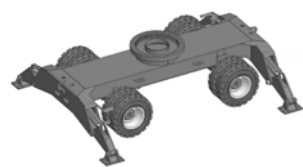

Standard-undercarriage



Standard-undercarriage

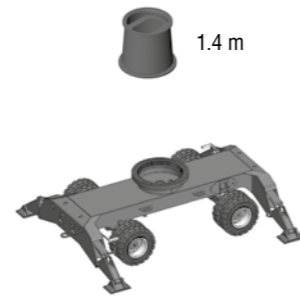

XL-undercarriage

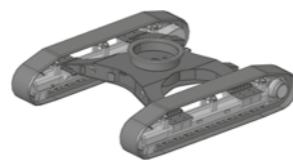

Crawler



Crawler

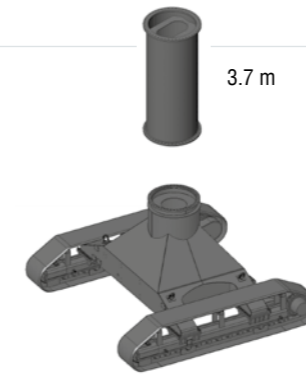

Crawler: XL-undercarriage

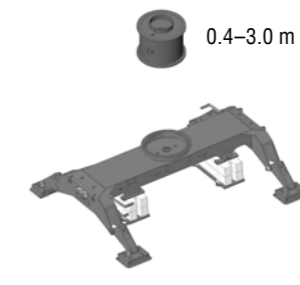

AHL standard-undercarriage



AHL Pylon



---

**[www.terex-fuchs.com](http://www.terex-fuchs.com)**

June 2024. Product specifications and prices are subject to change without notice or obligation. The photographs and/or drawings in this document are for illustrative purposes only. Refer to the appropriate Operator's Manual for instructions on the proper use of this equipment. Failure to follow the appropriate Operator's Manual when using our equipment or to otherwise act irresponsibly may result in serious injury or death. The only warranty applicable to our equipment is the standard written warranty applicable to the particular product and sale and Terex makes no other warranty, express or implied. © Terex Corporation 2024 - Terex, the Terex Crown design, Fuchs and Works For You are trademarks of Terex Corporation or its subsidiaries.

Terex® Deutschland GmbH | Industriestraße 3 | 76669 Bad Schönborn | Germany | Fon: +49 (0) 7253 84-0 | Fax: +49 (0) 7253 84-102 | [info@terex-fuchs.com](mailto:info@terex-fuchs.com)

